

**MODULES ABRI DE PROTECTION CIVILE NRBC-E  
MODELE 191-1**

**5 Modules**  
Surface habitable abri NRBC-E 26m<sup>2</sup>

Radier et dalles plafonds ép. 0.20m  
Voiles ép. 0.20m

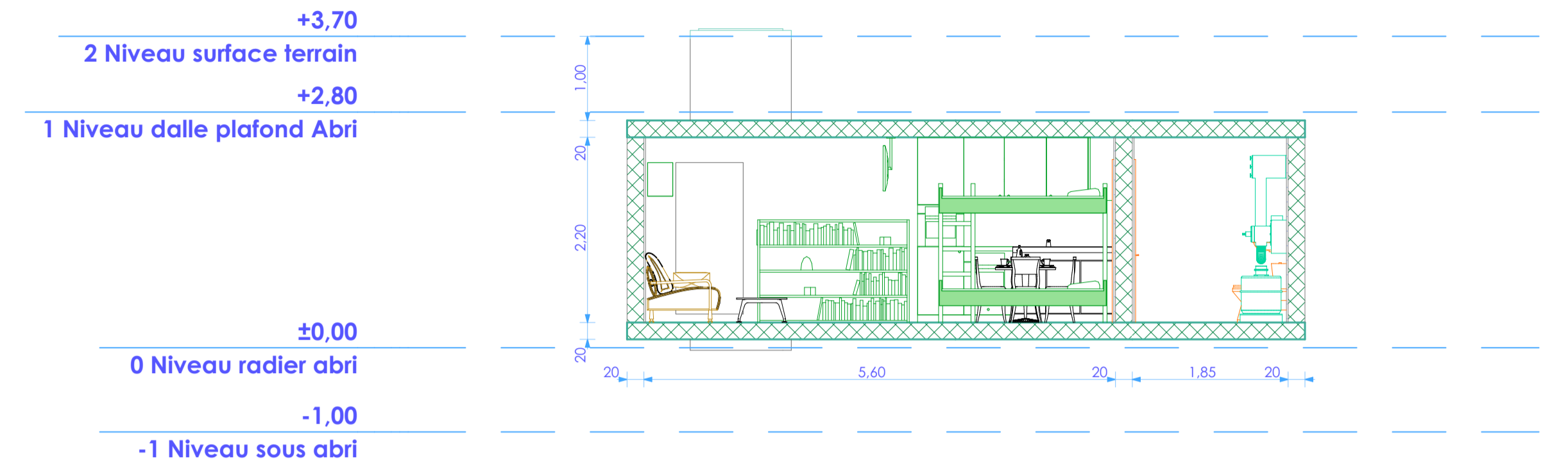

**B1** Coupe BB 1:57,59

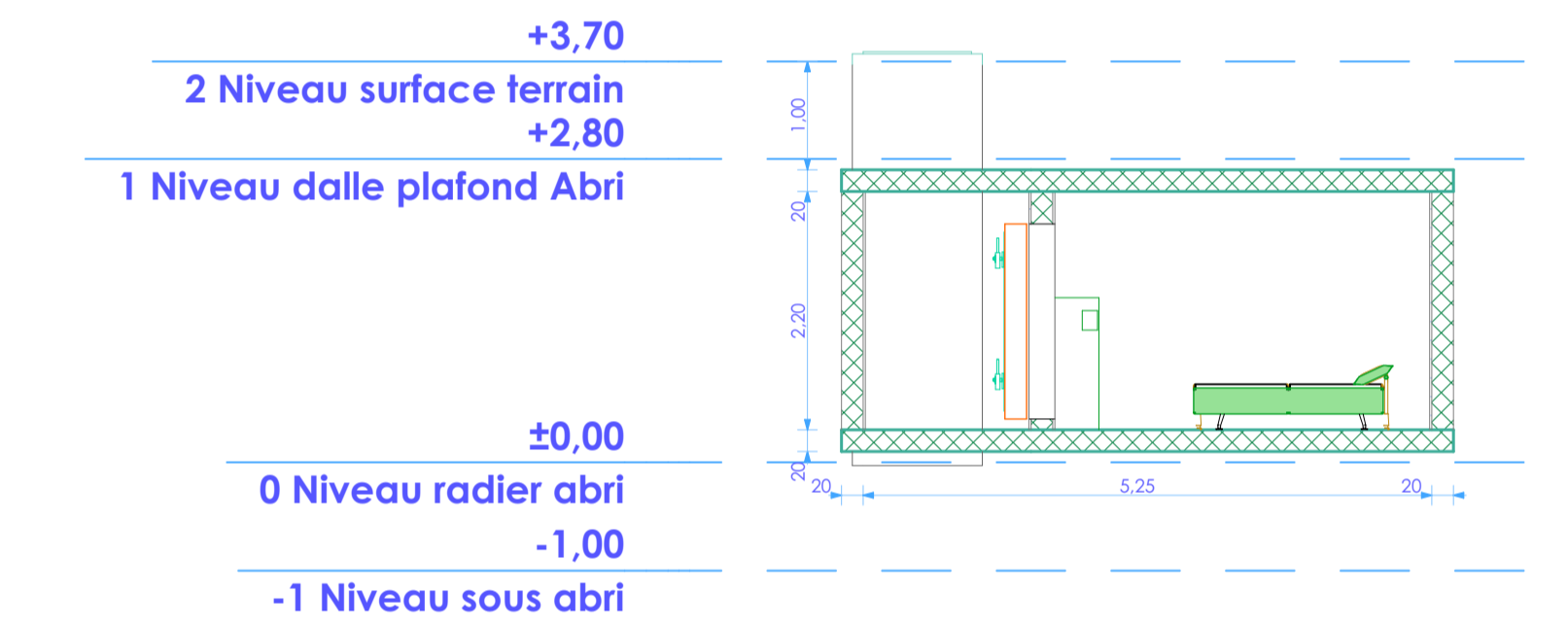

**B2** Coupe BB 1:67,84

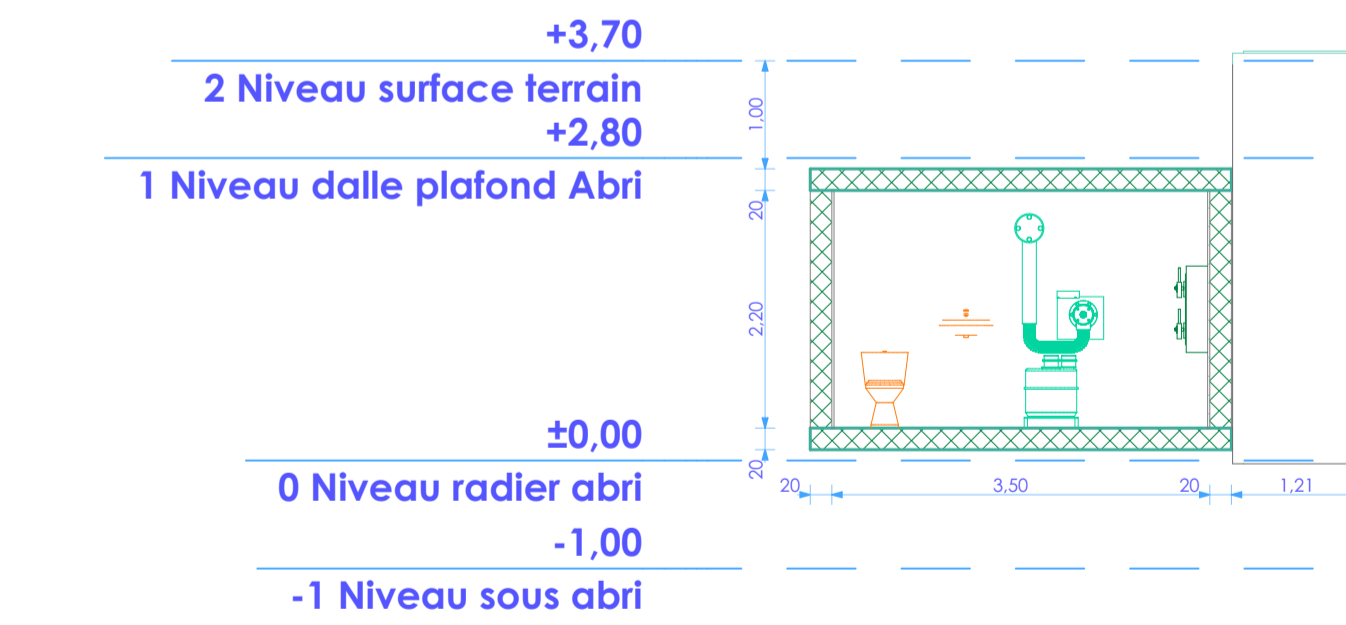

**B3** Coupe BB 1:70,00

**MODULES ABRI DE PROTECTION CIVILE NRBC-E  
MODELE 191-1**

**5 Modules**

Surface habitable abri NRBC-E 26m<sup>2</sup>

Radier et dalles plafonds ép. 0.20m  
Voiles ép. 0.20m

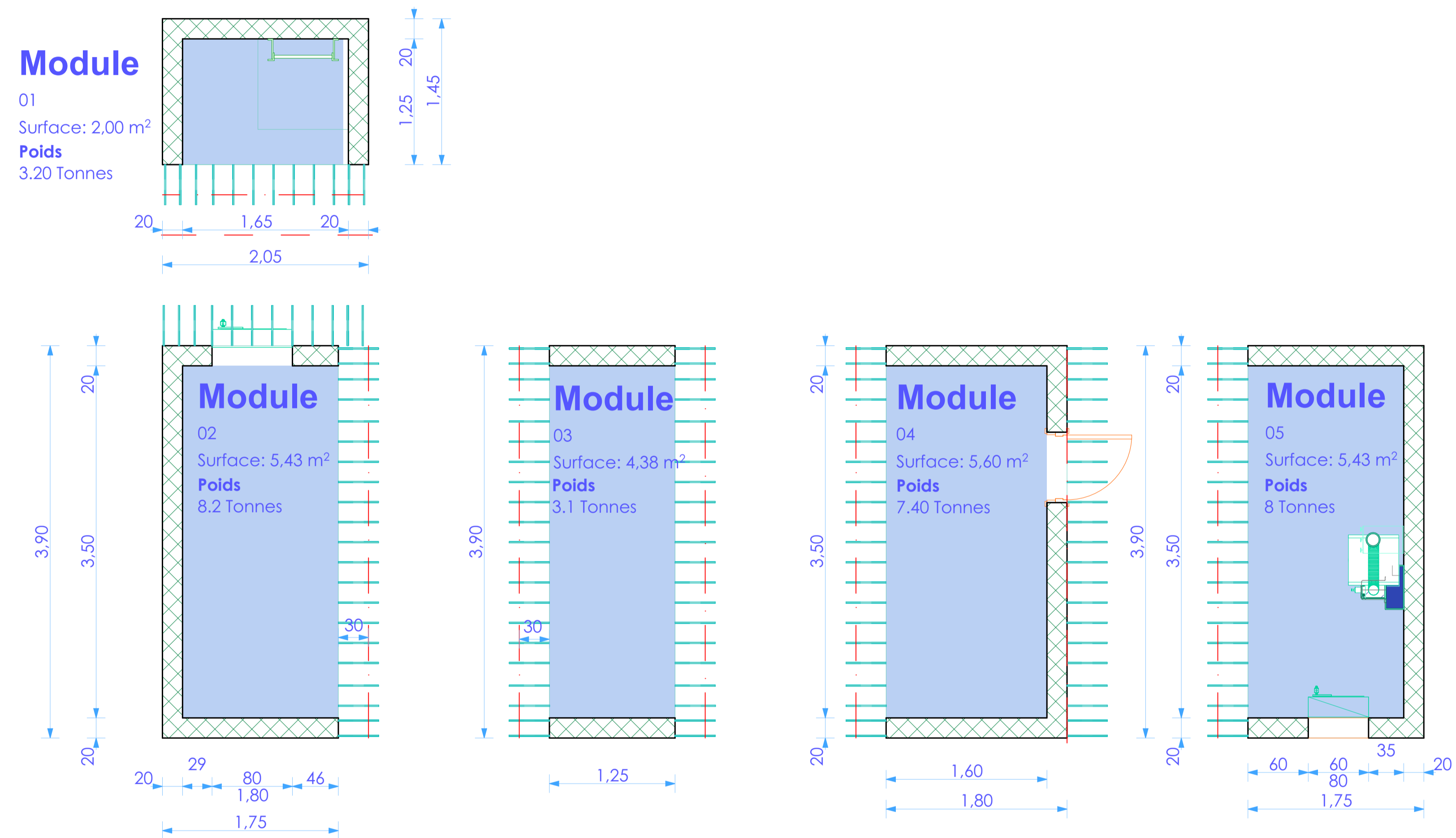

Surface du module apres scellage et coulage béton armé

